

80x80x25mm

AC AXIAL FAN

FAA1-08025 Series



Features:

- Motor: Shaded Pole Induction Motor
- Motor Protection: Impedance Protected
- Bearing Type: Two Ball or Sleeve
- Connection: UL 1430 AWG 22, 280mm Wire Leads or Terminal
- Frame Material: Aluminum Alloy
- Impeller Material: Plastic UL94V-0
- Operating Temp:
 - Two Ball: -10°C~70°C
 - Sleeve: -10°C~60°C
- Life Expectancy:
 - Two Ball: 50,000 Hours
 - Sleeve: 30,000 Hours



Fan-S Division



Model No.	Volt.	Freq.	Current	Power	Rated Speed	Maximum AirFlow		Maximum Static Pressure		Noise Level	Weight
	(VAC)	(Hz)	(A)	(W)	(rpm)	(CMM)	(CFM)	(InAq)	(mmAq)	(dB/A)	(g)
FAA1-08025N * H ** 31	115	50/60	0.08/0.07	7.40/5.80	2300/2800	0.481/0.594	17.0/21.0	0.099/0.125	2.515/3.600	21.2/27.8	210
FAA1-08025Q * H ** 31	230	50/60	0.07/0.06	15.18/13.11	2300/2800	0.481/0.594	17.0/21.0	0.099/0.125	2.515/3.600	21.2/27.8	210
FAA1-08025N * M ** 31	115	50/60	0.13/0.12	13.90/11.80	1900/2500	0.424/0.537	15.0/19.0	0.075/0.118	1.900/3.000	18.3/24.0	210
FAA1-08025Q * M ** 31	230	50/60	0.08/0.07	16.10/14.20	1900/2500	0.424/0.537	15.0/19.0	0.075/0.118	1.900/3.000	18.3/24.0	210

* Indicates "B" (Ball Bearing) or "S" (Sleeve Bearing)
 ** Indicates "W" (Wire Leads) or "T" (Terminal)

Noise is measured at the distance of one (1) meter from the axis of intake.

50Hz

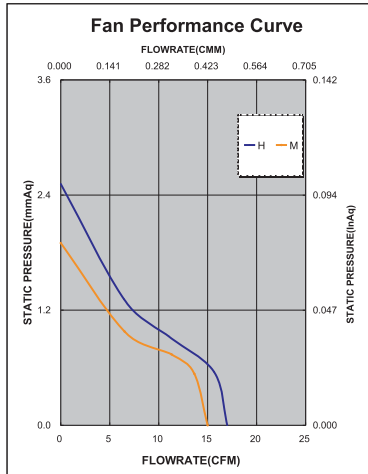

60Hz

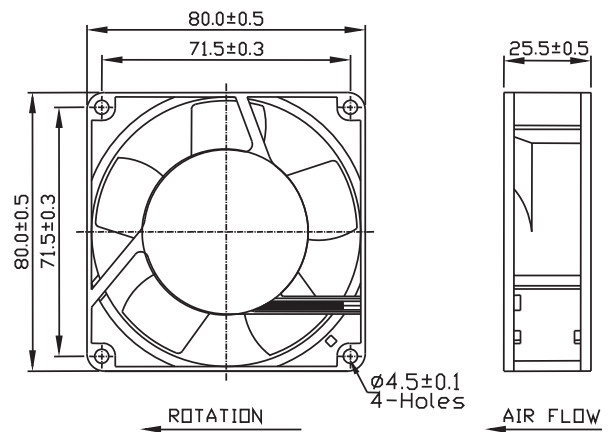
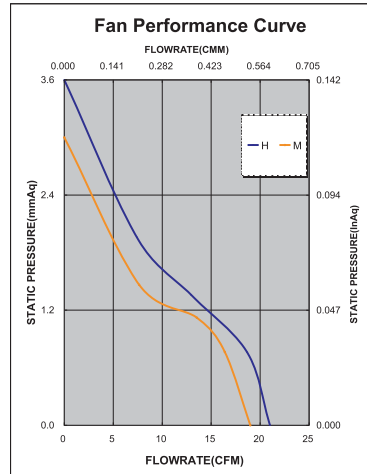

ISO-9001 Company

Qualtek
 Electronics Corporation

www.qualtekusa.com