

## DIGITUS® Modular Couplers for mounting in Patch Panels, shielded



DN-93906

✓ CAT 5e, CAT 6 & CAT 6 Class E<sub>A</sub>

✓ Shielded

✓ 2x RJ45 female

✓ Assignment: 1:1

### Abstract

DIGITUS® Modular Couplers, shielded, 2x RJ45 female, available as CAT 5e Class E, CAT 6 Class E and CAT 6 Class E<sub>A</sub>

### Features

- Suitable for mounting in Patch Panels
- 2x RJ45 female
- Material housing: Brass sheet, shining nickel plated
- Material PCB: FR4, 1.2 mm thickness
- Material contacts: Phosphor bronze
- Contacts coating: Nickel, gold plated 0.6 μ
- Mating cycles: ≥ 750
- Operating temperature: -10 °C up to +50 °C
- DN-93906 corresponds the channel requirements acc. to ISO/IEC 11801 Class E<sub>A</sub> up to 500 MHz

### Product Overview

The modular couplers from DIGITUS® are shielded and provide best performance and link quality for your network. They are equipped with 2 RJ45 sockets with the assignment 1:1 and are therefore suitable for mounting in Patch Panels.

### Product Number Information

DN-93906	DIGITUS® CAT 6 Class E <sub>A</sub> Modular Coupler, shielded, RJ45 to RJ45
DN-93613-1	DIGITUS® CAT 6 Class E Modular Coupler, shielded, RJ45 to RJ45
DN-93513	DIGITUS® CAT 5e Class E Modular Coupler, shielded, RJ45 to RJ45

### Product Images

DN-93513

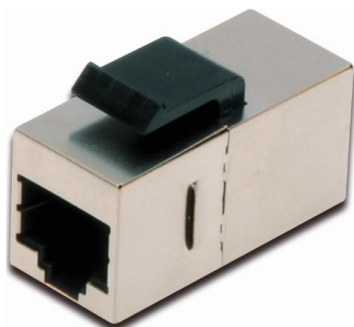

DN-93613-1

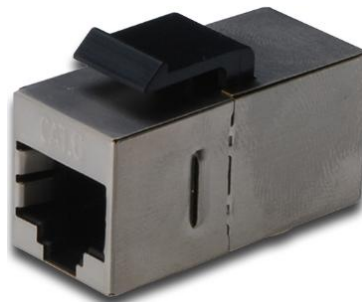

Technical Drawings

DN-93513

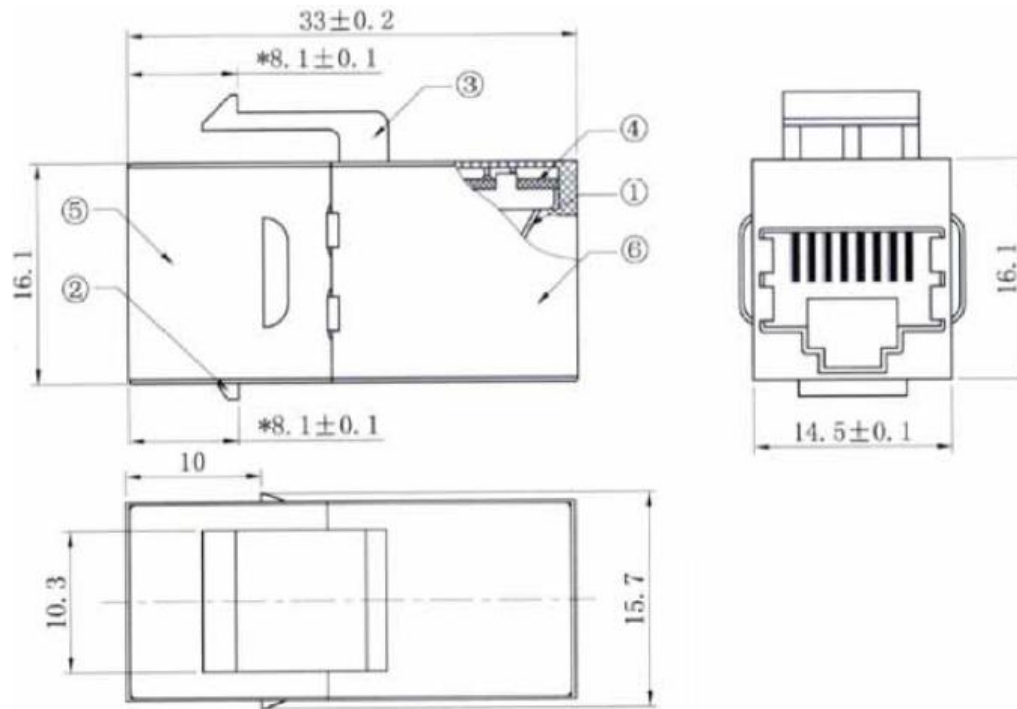

DN-93613-1

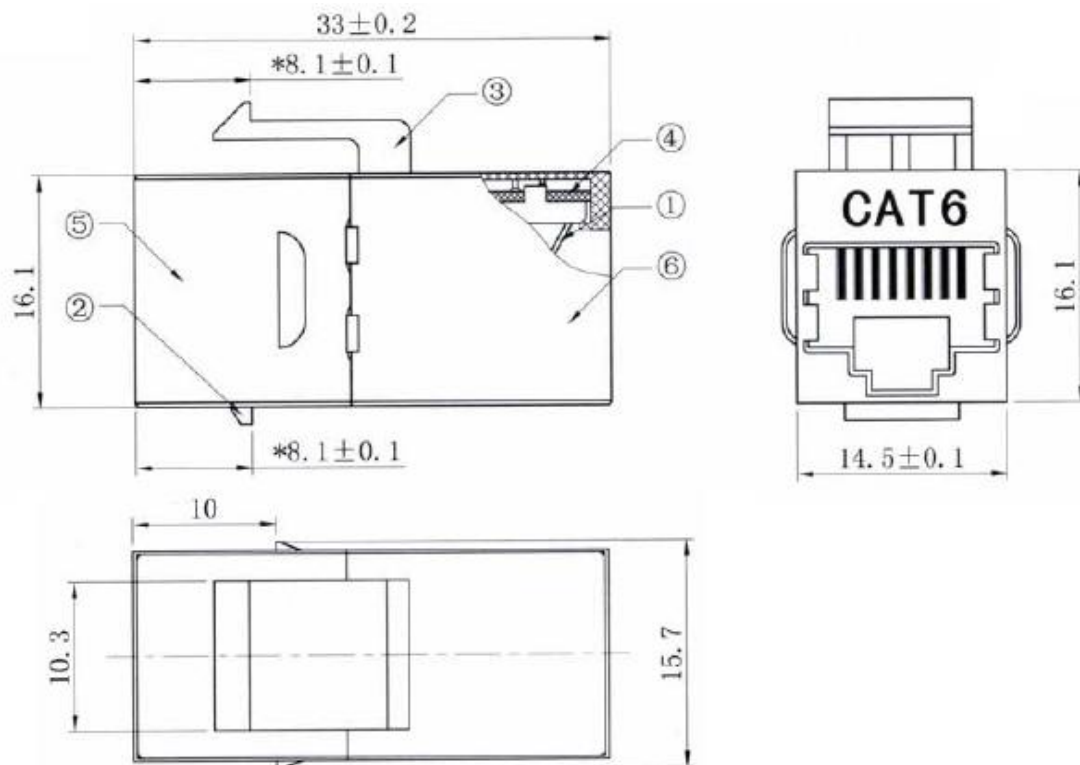

DN-93906

